

Clean Room Devices, LLC

CRD200 TUBING EXPANDER

OPERATIONS MANUAL

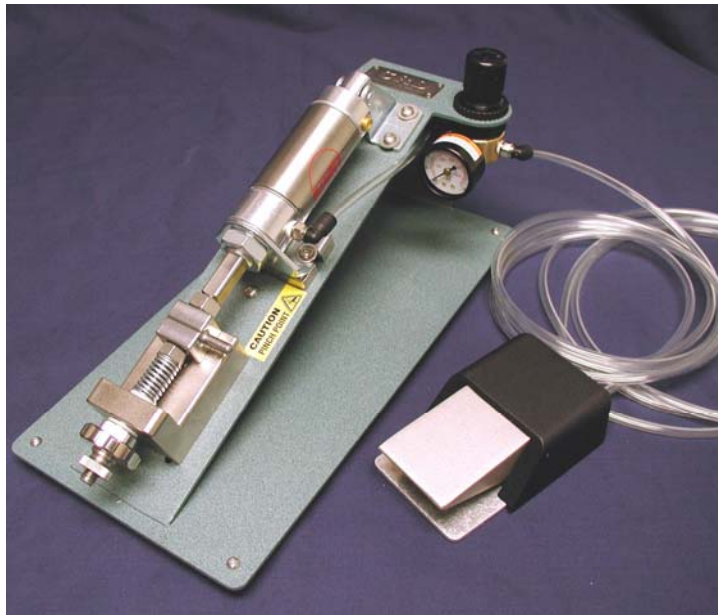

VERSION 1.0
LAST EDITED 8.22.05
DOCUMENT NUMBER 001
cleanroomdevices.com

Table of Contents

- Title Page.....1
- Table of Contents.....2
- 1.0 General Product & Safety Information.....3
 - 1.1 Product Information
 - 1.2 Safety Information
- 2.0 Installation.....3
 - 2.1 Air Supply
- 3.0 Operation.....4
 - 3.1 Tube Expanding
- 4.0 Troubleshooting.....5
- 5.0 Maintenance.....6
 - 5.1 Periodic Cleaning (annually)
- 6.0 Product Specifications.....6
- 7.0 Durometer Scale.....6
- 8.0 Parts List.....7
- 9.0 Warranty.....8
 - 9.1 Warranty
 - 9.2 Warranty period

1.0 General Product & Safety Information

1.1 Product Information

- Unit is designed to expand flexible tubing up to a durometer of Shore A 85 (Shore D 35), including any non-metallic braided materials
- The minimum/maximum inside tube diameter is 3/32" – 1/2"
- The expander jaws are universal in design to meet most applications
- The unit design allows for simple operator adjustment

1.2 Safety Information

- This product uses an air cylinder and foot pedal to pneumatically actuate the expanding jaws. The unit is not intended to expand anything other than flexible tubing.

WARNING

Avoid placing your fingers between the upper jaw block and the air cylinder mounting bracket while operating unit, sufficient pressure exists to cause personal injury.

- The desired air supply should be free of moisture/contaminates, and set to 80-100 psi. It is recommended that a suitable filter/regulator be installed onto the supply line prior to the unit to preserve the life expectancy of the air components.

2.0 Installation

Ensure all four (4) rubber feet are completely stabilized on your work surface prior to applying air pressure to the unit.

2.1 Air Supply

- Connect a 1/4" air supply hose to the fitting found on the regulator. The air supply should be free of moisture and contaminants. Standard facility compressed air within the range of 80-100 psi is recommended. Lower than 80 psi may affect the unit's ability to stretch properly with even pressure. Higher than 100 psi may reduce the life expectancy of working parts.

3.0 Operation

3.1 Tube Expanding

- Start by loosening the knurled *thumb-nut* to adjust the unit for the proper tubing size.
- Locate the lower expander jaw position for your tubing size using the larger *thumb-wheel* and engraved scale.

(This adjustment may require fine tuning depending on your tubing I.D., O.D., Durometer or material. It is recommended you note or log scale settings for future applications, or usage.)

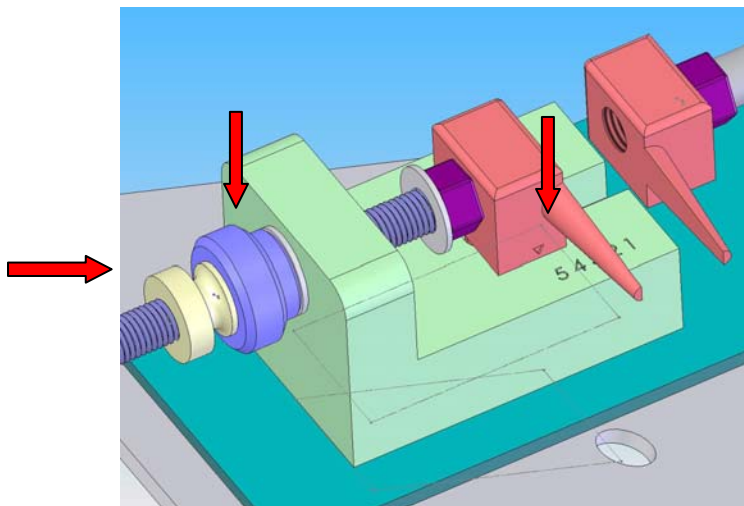

- Next, tighten the *thumb-wheel* against the lower mounting block and secure in place using the *thumb-nut*.
- Place the desired tubing over the ends of ***both*** expander jaws at the required depth.
- Actuate the expanding motion by fully depressing the foot pedal.
- Once the tube has been expanded the desired amount, release the foot pedal and immediately complete any secondary assembly application before the tubing regains its original size.

4.0 Troubleshooting

Operating Error	Action
Unit does not operate.	<ol style="list-style-type: none">1. Check the facility air connection.2. Check all air hose connections on the unit.
Jaws do not expand.	<ol style="list-style-type: none">1. Ensure there are no obstructions keeping the jaws from expanding.2. Completely depress the foot pedal to actuate.
Flexible tubing is splitting/tearing.	<ol style="list-style-type: none">1. Ensure the tubing being stretched does not exceed the recommended durometer.2. Ensure the lower jaw has been adjusted correctly for the tubing inside diameter (I.D.).3. Verify facility air supply psi or unit pressure adjustment.

5.0 Maintenance

5.1 Periodic Cleaning (annually)

- Wipe down outer surfaces with alcohol, septihol or mild detergents as required.

6.0 Product Specifications

Unit Weight	8 LBS / 3.5 KG
Overall Dimensions	15 in. (38cm) lg. x 7 in. (18cm) w. x 7 in. (18cm) ht.
Minimum/Maximum PSI	80 PSI / 100 PSI

7.0 Durometer Scale

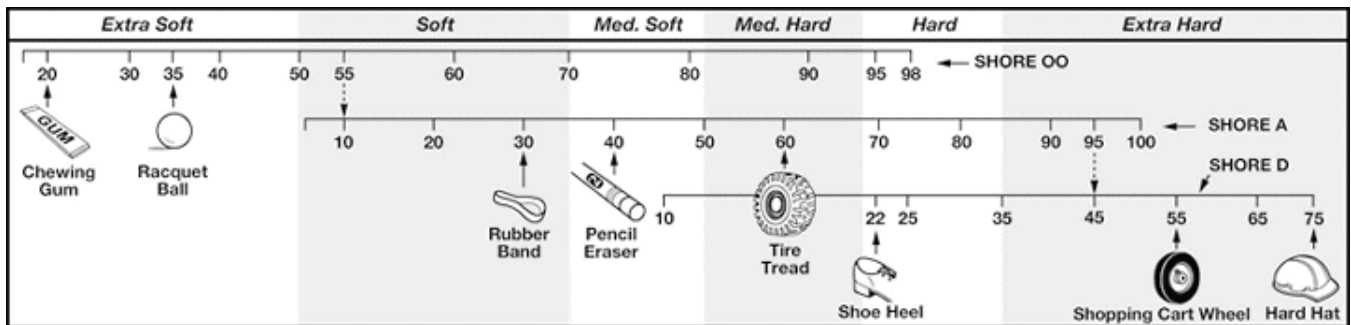

8.0 Parts List

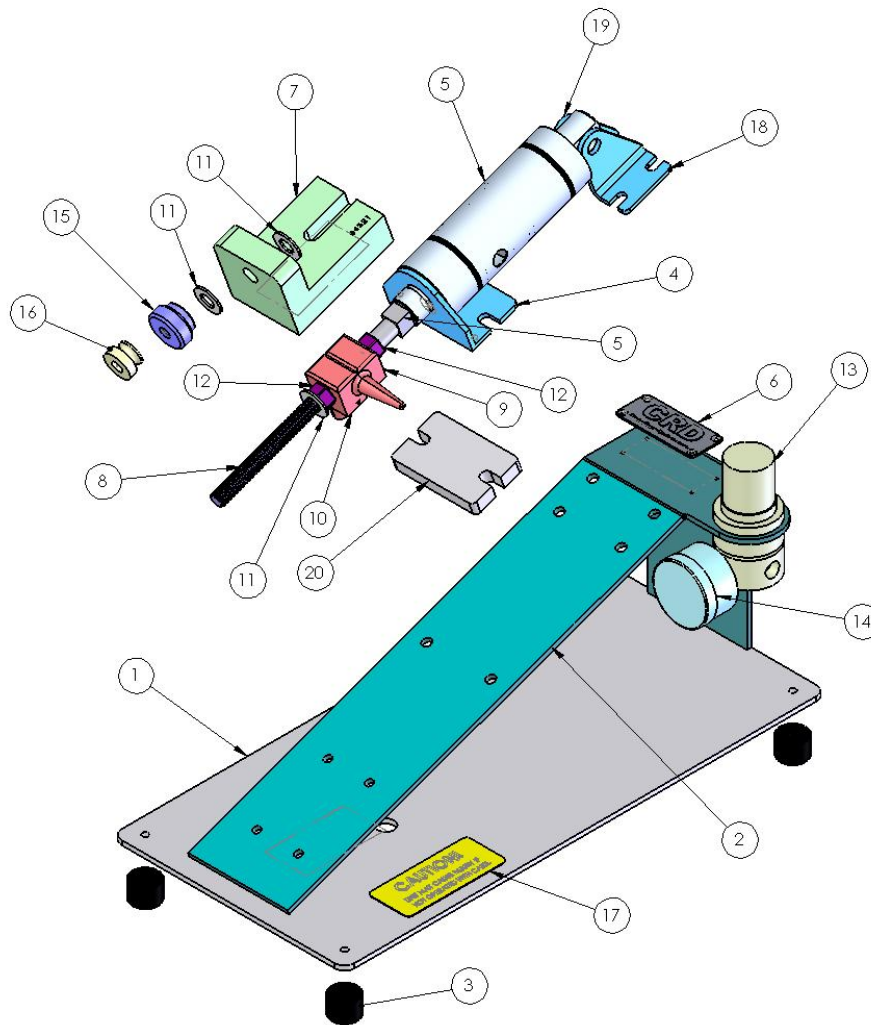

ITEM NO.	PART NUMBER	DESCRIPTION	QTY.
1	CD002-002	BASE PLATE	1
2	CD002-002	TOP PLATE	1
3	CD001-P22	FOOT, RUBBER, BLACK	4
4	D-241	BRACKET, MOUNTING, FRONT	1
5	NR-171-RP	AIR CYLINDER	1
6	CD001-027A	NAME PLATE	1
7	CD002-007A	BLOCK, MOUNTING, LOWER	1
8	.4375-20 set screw	ROD, THREADED	1
9	CD002-023	JAW, SPREADER, UPPER	1
10	CD002-024	JAW, SPREADER, LOWER	1
11	CD002-012	WASHER, FLAT	3
12	CD002-011	NUT, HEX	2
13	CD002-014	REGULATOR, AIR	1
14	CD002-013	GAUGE, AIR	1
15	CD002-010A	THUMB WHEEL	1
16	CD002-009	KNOB, TIGHTENING	1
17	CD002-015	LABEL, WARNING	1
18	CD002-003	BRACKET, MTG, REAR, RIGHT	1
19	CD002-017	BRACKET, MTG, REAR, LEFT	1
20	CD002-018	PLATE, SPACER	1

9.0 Warranty

9.1 Warranty

The manufacturer warrants the product manufactured by it, when properly installed, operated, applied and maintained in accordance with the procedures and recommendations outlined in the manufacturer's operation manual, to be free from defects in material or workmanship for a period as specified below, provided such defect is discovered and brought to the manufacturer's attention within the aforesaid warranty period.

The manufacturer will repair or replace any product or part determined to be defective by the manufacturer within the warranty period, provided such defect occurred in the normal service and not as a result of misuse, abuse, neglect or accident. Normal maintenance items requiring routine replacement are not warranted. The warranty covers parts and labor for the warranty period unless otherwise specified. Repair or replacement shall be made at the factory or the installation site, at the sole discretion of the manufacturer. Any service performed on the product by anyone other than the manufacturer must first be authorized by the manufacturer.

Unauthorized service voids the warranty and any resulting charge or subsequent claim will not be paid. Products repaired or replaced under warranty shall be warranted for the unexpired portion of the warranty applying to the original product.

The foregoing is the exclusive remedy of any buyer of the manufacturer's product. The maximum damages liability of the manufacturer is the original purchase price of the product or part.

THE FORGOING WARRANTY IS EXCLUSIVE AND IN LIEU OF ALL OTHER WARRANTIES, WHETHER WRITTEN, ORAL, OR STATUTORY, AND IS EXPRESSLY IN LIEU OF THE IMPLIED WARRANTY OF MERCHANTABILITY AND THE IMPLIED WARRANTY OF FITNESS FOR A PARTICULAR PURPOSE. THE MANUFACTURER SHALL NOT BE LIABLE FOR LOSS OR DAMAGE BY REASON OF STRICT LIABILITY IN TORT OR ITS NEGLIGENCE IN WHATEVER MANNER INCLUDING DESIGN, MANUFACTURE OR INSPECTION OR THE EQUIPMENT OR ITS FAILURE TO DISCOVER, REPORT, REPAIR, OR MODIFY LATENT DEFECTS INHERENT THEREIN.

THE MANUFACTURER, HIS REPRESENTATIVE OR DISTRIBUTOR SHALL NOT BE LIABLE FOR LOSS OF USE OF THE PRODUCT OR OTHER INCIDENTAL OR CONSEQUENTIAL COSTS, EXPENSES, OR DAMAGES INCURRED BY THE BUYER, WHETHER ARISING FROM BREACH OF WARRANTY, NEGLIGENCE OR STRICT LIABILITY IN TORT.

The manufacturer does not warrant any product, part, material, component, or accessory manufactured by others and sold or supplied in connection with the sale or manufacturer's products.

9.2 Warranty Period

Parts and labor for one (1) year from the date of shipment from the factory. Freight to the factory on units that the manufacturer requests to be returned shall be paid by the purchaser, all return freight to be paid by the manufacturer; means of transportation to be specified by the manufacturer.

*For additional information contact your local representative or;
visit www.cleanroomdevices.com*