



CLEAN ROOM DEVICES, LLC
"WHERE TUBING AND FITTINGS COME TOGETHER"

CRD600 Automatic Fitting Inserter

OPERATIONS MANUAL



VERSION 2.0
LAST EDITED 03.08.11
DOCUMENT NUMBER 001
cleanroomdevices.com

Table of Contents

| | |
|---|----|
| Title Page..... | 1 |
| Table of Contents..... | 2 |
| 1.0 General Product & Safety Information..... | 3 |
| 1.1 Product Information | |
| 1.2 Safety Information | |
| 2.0 Installation/Setup..... | 4 |
| 3.0 Operation..... | 10 |
| 4.0 Maintenance..... | 10 |
| 4.1 Removing Cover | |
| 4.2 Periodic Cleaning | |
| 5.0 Recommended Spare Parts..... | 11 |
| 6.0 Product Specifications..... | 11 |
| 7.0 Trouble Shooting..... | 11 |
| 8.0 Durometer Scale..... | 12 |
| 9.0 Parts List..... | 12 |
| 10.0 Electrical & Pneumatic Diagrams..... | 14 |
| 11.0 Warranty..... | 16 |
| 11.1 Warranty | |
| 11.2 Warranty Period | |
| 12.0 Alcohol Dispenser Option..... | 18 |

1.0 General Product & Safety Information

1.1 Product Information

- The Automatic Fitting Inserter is designed to hold and locate soft tubing while inserting a fitting into the tubing.
- The minimum/maximum outside tube diameter is 3/32" to 9/16"

1.2 Safety Information

- This product uses air cylinders and electronic sensors to pneumatically actuate the closing jaws. The unit is not intended for anything other than flexible tubing.
- The desired air supply should be free of moisture/contaminates, and a minimum 100 psi facility air supply is recommended. It is also recommended that a suitable filter/regulator be installed onto the supply line prior to the unit to preserve the life expectancy of the air components.

CRD600 AUTOMATIC FITTING INSERTER

SAFETY NOTICE

PLEASE READ CAREFULLY BEFORE CONTINUING

Warning

The “CRD600 Automatic Fitting Inserter should only be operated by trained, qualified personnel, who have read and understand this manual.

The owner of this CRD600 is responsible for training all personnel to properly operate this unit. Failure to follow instructions may result in serious personal injury.

Never, under any circumstances operate the “Automatic Fitting Inserter” with the cover or guarding removed or any safety device disabled.

At the time of this writing the content of this manual was up-to-date. However, due to continual improvements in unit design, it is possible some descriptions and procedures contained herein vary from the unit actually delivered to you.

2.0 Installation/Setup

Ensure all five (5) rubber feet are completely stabilized on your work surface prior to applying air pressure to the unit.

2.1 Air Supply

- Connect a 1/4" air supply hose to the fitting found on the back of the Automatic Fitting Inserter. The air supply should be free of moisture and contaminants and supplies **80-120 psi**. It is important to have the ability to shut off the air pressure or disconnect from the main air line. A quick-connect coupling or ball valve is recommended. (See Figure 1)
- The air supply will need to be off or disconnected when manually cycling the pin set actuation air cylinder.
- Adjust low pressure regulator between 20-30 psi. (Shown in Figure 2)
DO NOT set higher than 30 psi as this can damage the unit.
- Adjust high pressure regulator between 80-120 psi. (Shown in Figure 2)
Must have a minimum of 80 psi to function properly.

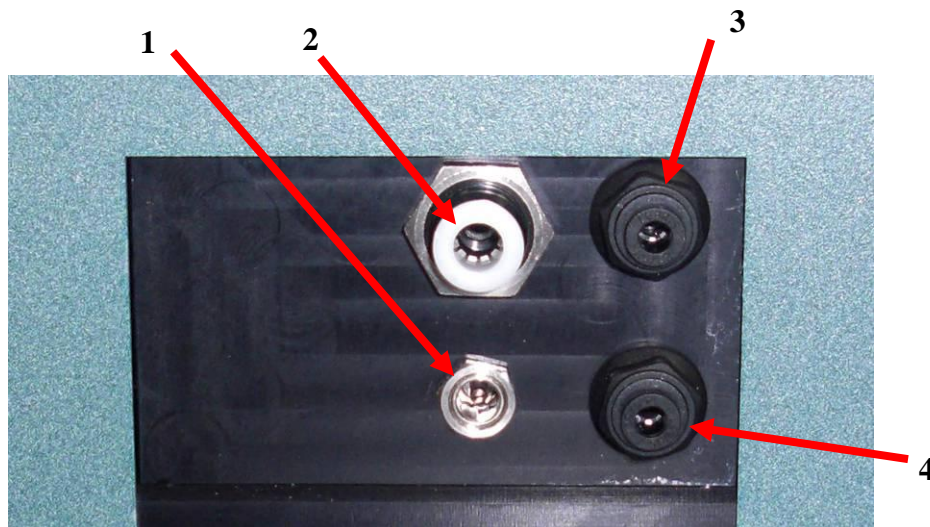

Figure 1 - Rear Panel Layout

1. 24 VDC Power Supply Jack
2. Compressed Air Supply, use 1/4" tubing
3. Air Supply to Alcohol Dispenser
4. Return from Alcohol Dispenser

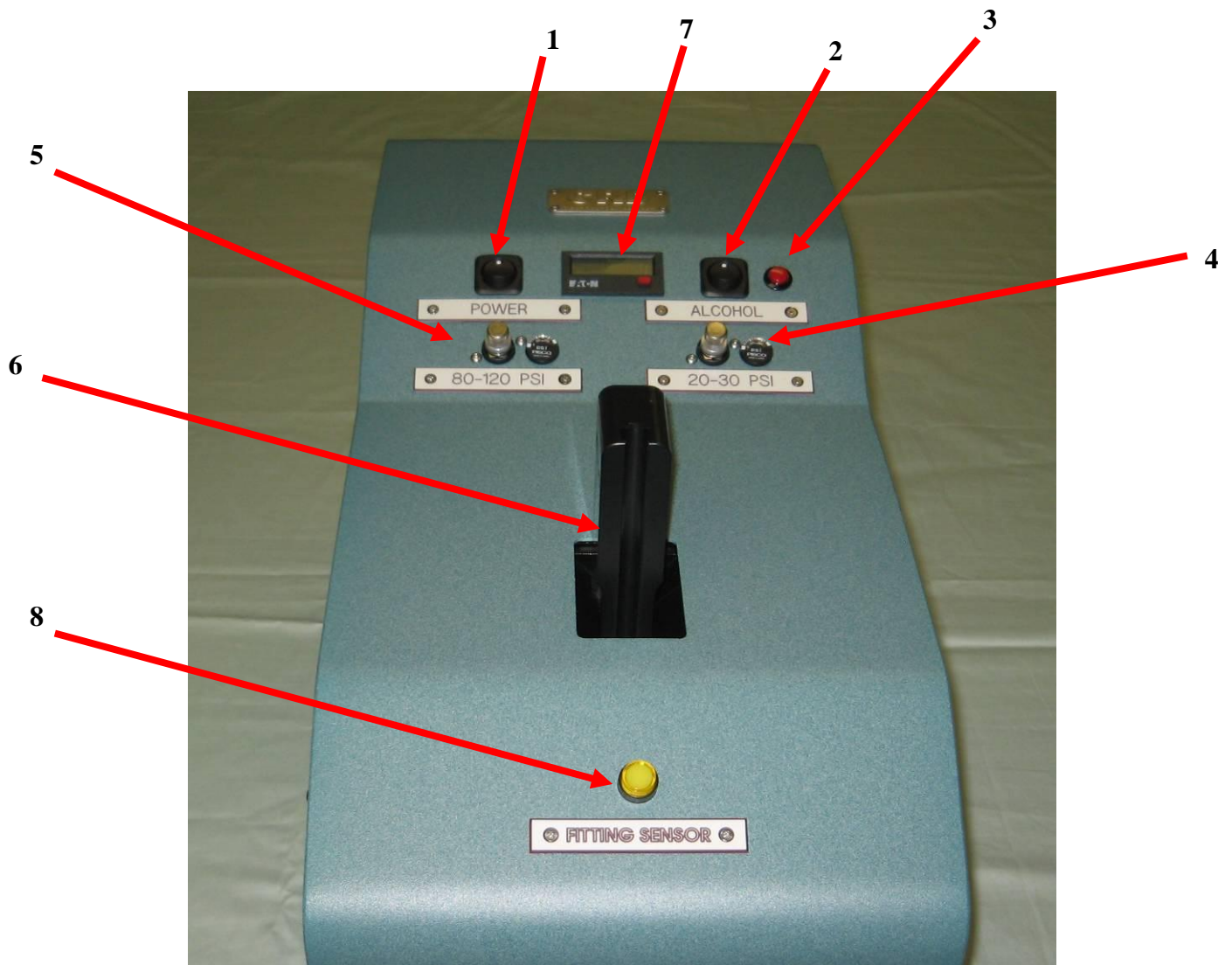

Figure 2 - Front Panel Layout

1. Power On/Off Switch
2. Alcohol Dispenser On/Off Switch
3. Alcohol Primer On/Off Switch
4. Low Pressure, Regulator/Gauge
5. High Pressure, Regulator/Gauge
6. Magazine
7. Operational Counter with reset
8. Fitting Sensor

2.2 Electrical

- Plug the electrical connector into the back of the Automatic Fitting Inserter and plug the 24V power supply into an 110V AC outlet. **The smart relay inside the machine has an 8 second power up time before the Automatic Fitting Inserter becomes fully operational.**

2.3 Pin Set Installation (*Air supply must be disconnected*)

- Remove the magazine from the unit and loosen the six button head screws on both sides of the cover. Lift up the cover and carefully place on left side of base as wire and air lines are connected from cover to unit.
- The CRD600 is equipped with a Pin Set Assembly which is designed for a specific tube fitting.
- Roll the pin on a flat surface to insure that it is straight.
- Insert the pin tip into the hole near the bottom of the magazine rack. Slide the pin through the hole until it is horizontal within the CRD600 (Shown in figure 3 below).
- Push the pin toward the back of the unit until the threaded end reaches the threaded cylinder rod. Turn the pin clockwise to tighten. **Ensure both threaded parts are clear of any sand or other particulates, as a crooked pin can cause severe damage to the CRD600.**
- Once the pin is hand-tightened, pull the pin forward exposing the cylinder (Shown in figure 4 below). Place a wrench on the flats of the cylinder rod and hold in place.
- Place the 5/16" open end wrench onto the flats of the pin set and turn to secure the pin into the cylinder rod (Shown in figure 5 below).
- Manually pull the pin forward to ensure it goes through the magazine and into the jaw set.

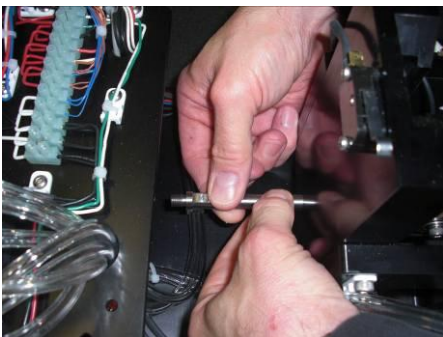

Figure 3 - Aligning the pin

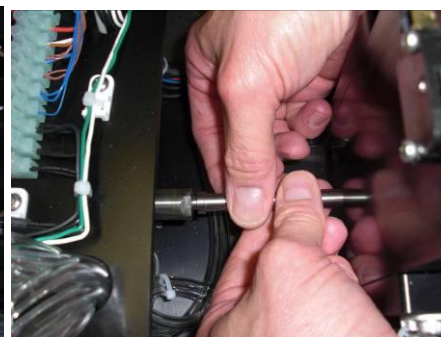

Figure - 4 Threading pin to cylinder

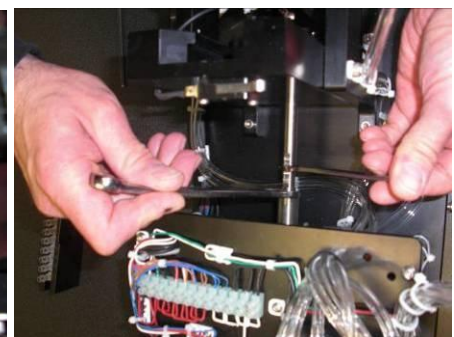

Figure - 5 Tightening pin to cylinder

2.4 *Jaw Set Installation (Air supply must be disconnected)*

- With the cover off, loosen the four 5mm screws holding the jaws into the block
- Remove the jaws and replace with new set.
- **Retighten the four 5mm screws.**
- **Check the pin-jaw alignment for pin concentricity.** With the air turned off and the magazine in, place a piece of tubing in the jaw set and clamp the tubing manually with the jaws. Pull the pin forward manually through the magazine and ensure that it lines up with the center of the inner diameter of the tubing. Gently rotate the pin to ensure that there is no wobble in the pin head. **Failure to do so may result in severe damage to both the magazine and jaw set!**
If any wobble is detected, recheck that the threads on the cylinder and pin set are clean. If there is still a wobble, the Pin Set Assembly is bad and another must be used.

2.5 *Adjusting the Stop Gate*

- The distance between the end of the jaw set and the stop gate may need to be adjusted according to what fitting is being used. This distance to adjust the stop gate is determined by the gap between the fitting flange and the end of the tubing. Sliding the stop gate away from the front of the unit will insert the fitting deeper into the tubing. Figures 6 and 7 below show the tubing before adjusting the stop gate and after adjusting the stop gate:



Figure 6
Unadjusted Stop Gate



Figure 7
Adjusted Stop Gate

- To adjust this distance, loosen the one 5mm socket cap screw on the side of the gate and move the gate in or out depending on the stick out desired (figures 8 and 9 below). Re-tighten the screw before attempting to run the unit.

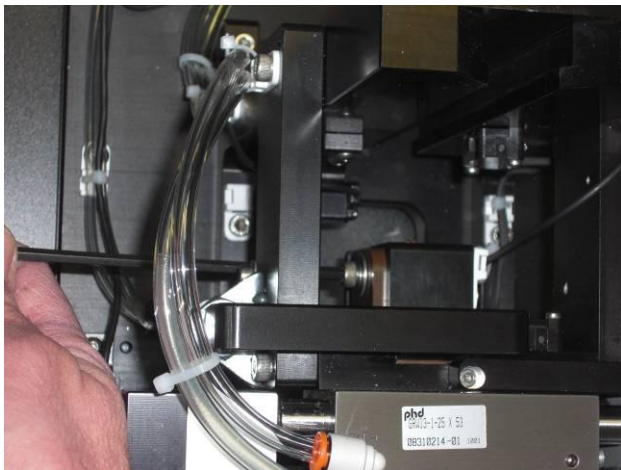

Figure 8 - Loosening the socket head cap screw

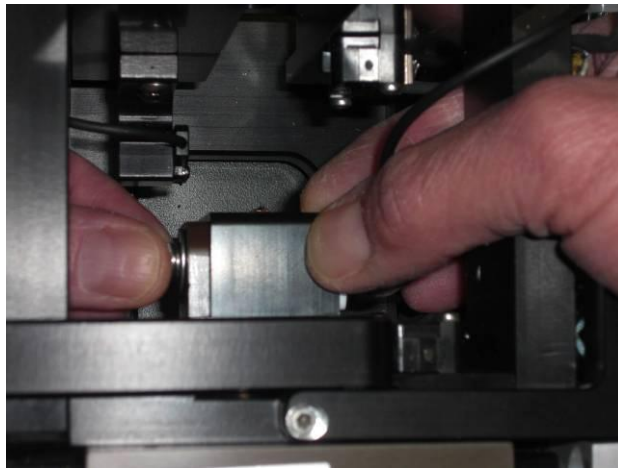

Figure 9 - Sliding the gate forward

- If the fitting is not being fully inserted, adjust the gate backwards, towards the pin. If the fitting is being pushed on too far, or the tubing is rolling, adjust the gate forward, toward the operator. Verify that the tip of the pin set is well centered with the jaw set in both a left-to-right view point and an up-and-down view point.
- Close the Cover on the CRD600 and tighten the 6 button head screws on each side.

Notice: It is not recommended to operate the **CRD600** with the cover open.

2.6 *Magazine Installation*

- Select the appropriate magazine that corresponds to the fitting being installed.
- Slide the fittings into the slot on the magazine so that the barbed end (the end you will insert into the tube) is protruding. Put enough parts into the magazine to fill it.
Always have at least five fittings in the magazine or a jam may occur.
- Place the magazine into the magazine rack with the parts facing the jaw set.
- Check to see that the fittings have fully settled into the magazine.
- With the air turned off, pull the pin forward and verify the pin set enters the magazine and the fitting, and drives the fitting forward into the jaws.
- **Last Fitting Position Sensor** – Units equipped with a last fitting position sensor have an added layer of safety. If the lower-most fitting in the magazine is not seated correctly, the sensor will pick this up and the unit will not fire. This prevents the pin set from crashing into the last fitting and damaging the pin set or magazine.

When no fitting is present or the fitting is not properly aligned, only the red ‘power on’ LED will be on and amber sensor LED will be off.

If a fitting is properly seated in the magazine, the sensor will detect this and display a Amber LED as well as the single red ‘power on’ LED. Shown in the figures below is the sensor with and without fittings.

**THIS SENSOR'S POSITION IS A FACTORY SETTING, ANY ADJUSTMENT
COULD CAUSE DAMAGE TO YOUR PIN SET, MAGAZINE OR JAW SET.**

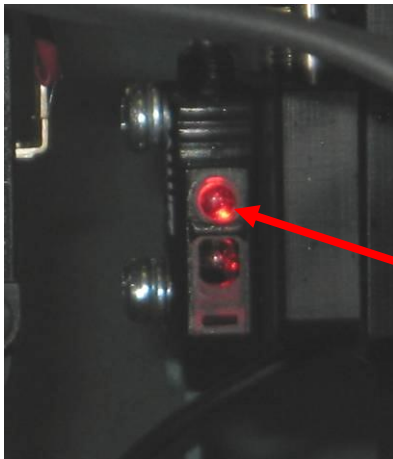

Sensor Power

Fitting detected

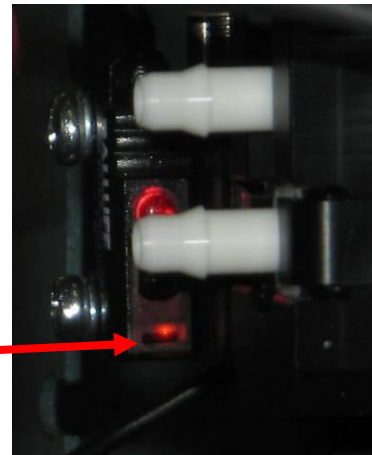

Figure 7 - Sensor without fittings

Figure 8 - Sensor with Fittings

Adjusting Last Fitting Position Sensor – By adjusting the sensor up or down, you can position the sensor properly. As in Figure 9, when a .015 - .020 feeler gauge is placed on the magazine shelf to raise the magazine up, the amber light should turn off. When the feeler gauge is taken away and the magazine drops down, the amber light should be back on.



Figure 9 - Magazine with feeler gauge

3.0 Operation

3.1 *Loading Nest and Jaws*

- ***Hook up the air FIRST and then turn on the power***
- Fill the magazine with fittings (5 minimum)
- Insert a tube into the jaws, pushing forward until gate switch is hit.
- Unit will cycle pushing the fitting into tube and then dropping the assembly down

3.2 *Fitting Sensor Lamp*

- Yellow lamp is always on when machine is operating. If lamp is out it indicates that the magazine is empty of fittings or the fitting is not all the way down in the proper position in the magazine.

4.0 Maintenance

4.1 *Daily*

- **Once each day:** the pin set should be retightened onto the air cylinder. Loose pin sets can result in damage to the unit.
- **Once each day:** ensure that the screws holding the jaws on are tight. Loose screws will allow the jaws to move enough that fittings may not properly insert into the tubing.
- **Once each day:** disconnect the air at the rear of the unit and pull the pin set toward the magazine hole and be sure that it enters the hole freely (without hanging up on the side-wall). The pin set must enter the magazine hole without moving the magazine or damage can occur.

4.2 *Every 3 months*

- **Once every three months,** the lid should be opened and the inside around the jaw set and magazine should be cleaned via air (no more than 30psi). This will remove any dust that has collected. At this time, air connectors on the manifold should be checked for tightness. The pin-set should be checked to make sure it is tight. Any dust or debris which the blown air did not clean up should be wiped away.
- Wipe down outer surfaces with alcohol, septihol or mild detergents as required.

5.0 Recommended Spare Parts

It is strongly recommended that you keep at least the following components on-hand to minimize downtime should a component wear out or break.

- 1 additional Pin Set Assembly
- 1 additional Magazine
- 1 additional Jaw Set

6.0 Product Specifications

| | |
|---------------------|---|
| Unit Weight | 37 LBS / 17 KG |
| Overall Dimensions | 19.25 in. (48.9cm) lg. x 9.15 in. (23.2cm) w. x 10.3 in. (26.2cm) ht. |
| Minimum/Maximum PSI | 80 PSI /100 PSI |

7.0 Trouble Shooting

| Operating Error | Action |
|---|---|
| Unit does not operate. | <ol style="list-style-type: none"> 1. Check the facility air connection. 2. Check both regulators are set to the proper pressure 3. Check electrical power, 110VAC & 24 VDC 4. Check all safeties: <ul style="list-style-type: none"> • Cover switch-make sure cover is completely on • Magazine switch-make sure magazine is pushed down all the way in the magazine rack • Optional last fitting sensor- verify last fitting is in position |
| Tubing does not go on the fitting / all the way on. | <ol style="list-style-type: none"> 1. Adjust Stop Gate position 2. Adjust high pressure, should be 80-120 psi. |
| | |

8.0 Durometer Scale

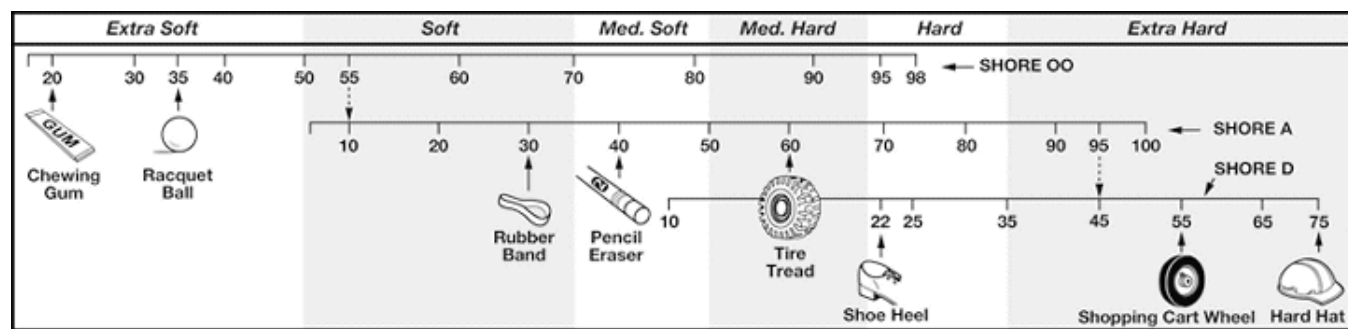

9.0 Parts List

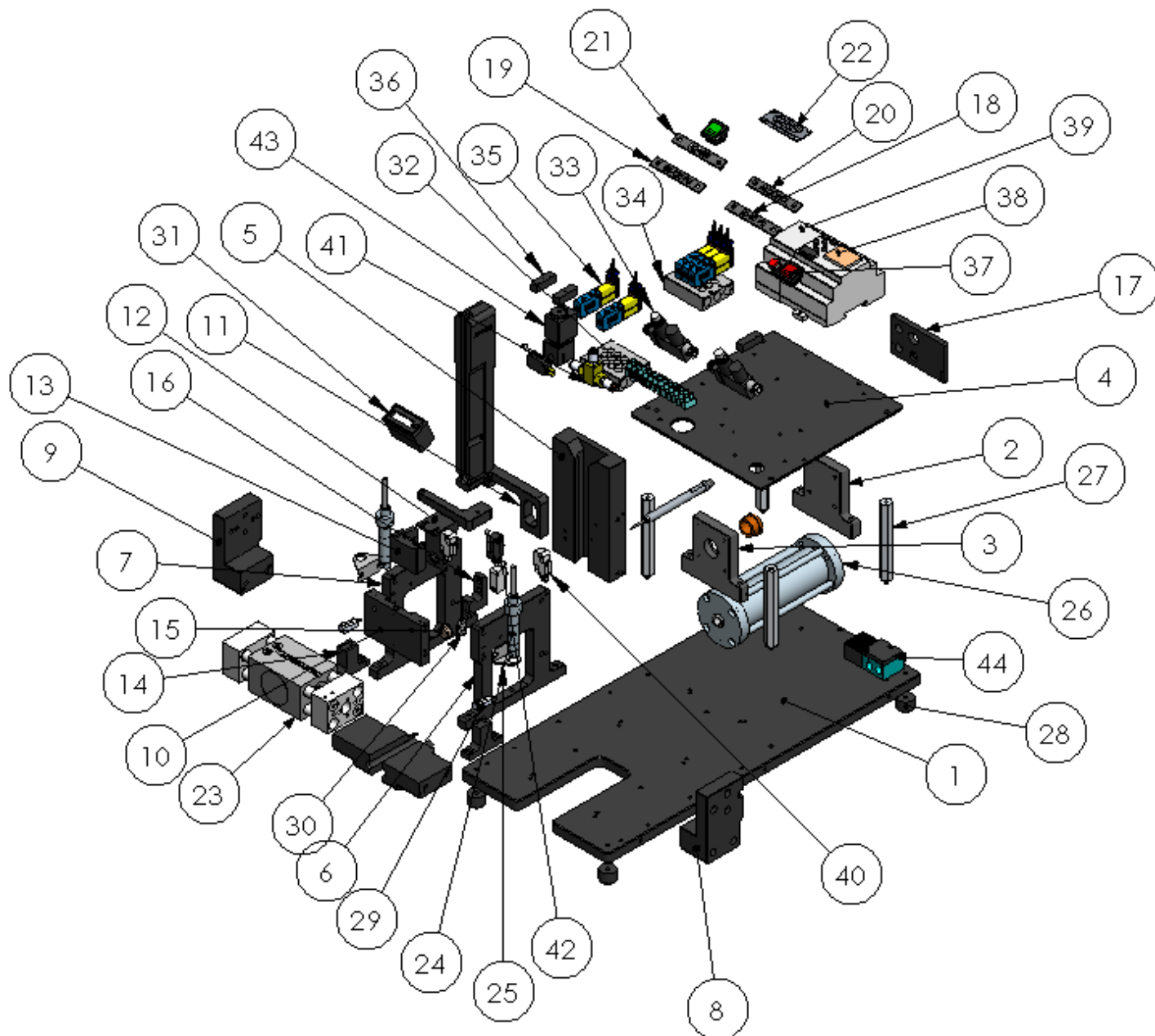

| | | | |
|----|---|-----------|--|
| 1 | 1 | CD006-001 | BASE PLATE- AFI 2000 |
| 2 | 1 | CD006-002 | REAR CYLINDER MOUNT |
| 3 | 1 | CD006-003 | FRONT CYLINDER MOUNT |
| 4 | 1 | CD006-004 | MOUNT PLATE, UPPER |
| 5 | 1 | CD006-005 | GUIDE BLOCK, MAGAZINE |
| 6 | 1 | CD006-006 | SIDE SUPPORT, GRIPPER, RIGHT |
| 7 | 1 | CD006-007 | SIDE SUPPORT, GRIPPER, LEFT |
| 8 | 1 | CD006-008 | UPPER JAW MOUNT, RIGHT |
| 9 | 1 | CD006-009 | UPPER JAW MOUNT, LEFT |
| 10 | 1 | CD006-010 | CROSS BEAM |
| 11 | 1 | CD006-011 | ACTUATOR DRIVE ARM |
| 12 | 1 | CD006-012 | BRACKET, STOP GATE BUTTON |
| 13 | 1 | CD006-013 | STOP GATE |
| 14 | 2 | CD006-014 | SENSOR MOUNT GRIPPER |
| 15 | 1 | CD006-015 | SENSOR BUTTON |
| 16 | 1 | TS-00135 | SENSOR MOUNT |
| 17 | 1 | CD004-041 | SERVICE PANEL |
| 18 | 1 | CD006-017 | NAME PLATE, 20-30 PSI |
| 19 | 1 | CD006-018 | NAME PLATE, 80-120 PSI |
| 20 | 1 | CD006-019 | NAME PLATE, ALCOHOL |
| 21 | 1 | CD006-020 | NAME PLATE, POWER |
| 22 | 1 | CD001-027 | PLATE, CRD COMPANY I.D. |
| 23 | 1 | P00105 | PHD GRIPPERS GRW13-5-25-53-L1-UB99 |
| 24 | 1 | P00212 | BIMBA AIR CYLINDER |
| 25 | 1 | P00215 | BIMBA AIR CYLINDER MOUNTING BRACKET |
| 26 | 1 | P00216 | BIMBA 4.5 AIR CYLINDER |
| 27 | 1 | CD006-021 | STANDOFF, MODIFIED |
| 28 | 5 | P00026 | RUBBER FOOT |
| 29 | 2 | P00106 | JAW OPEN/CLOSE SENSOR |
| 30 | 1 | TS00137 | LAST FITTING SENSOR |
| 31 | 1 | P00001 | ALLIED VEEDER ROOT COUNTER |
| 32 | 1 | P00217 | TERMINAL STRIP, 12 POLE |
| 33 | 2 | P00167 | PISCO AIR REGULATOR |
| 34 | 2 | P00091 | MANIFOLD, MAC VALVES |
| 35 | 5 | P00093 | MAC SOLENOID |
| 36 | 3 | P00192 | SOLENOID BLANK BLOCK |
| 37 | 1 | P00165 | ROUND ROCKER SWITCH |
| 38 | 1 | P00107 | IDEC SMART RELAY |
| 39 | 1 | P00195 | IDEC SMART RELAY MODULE |
| 40 | 3 | P00011 | SWITCH, MINATURE, SNAPPING-ACTING |
| 41 | 1 | P00211 | JUMBO SHUTTLE VALVE |
| 42 | 1 | P00048 | SWITCH, SAFETY, INTERLOCK |
| 43 | 1 | P00169 | VITON VALVE (ALCOHOL OPTION) |
| 44 | 1 | P00108 | MAC VALVE, 4 WAY |

10.0 Electrical & Pneumatic Diagrams

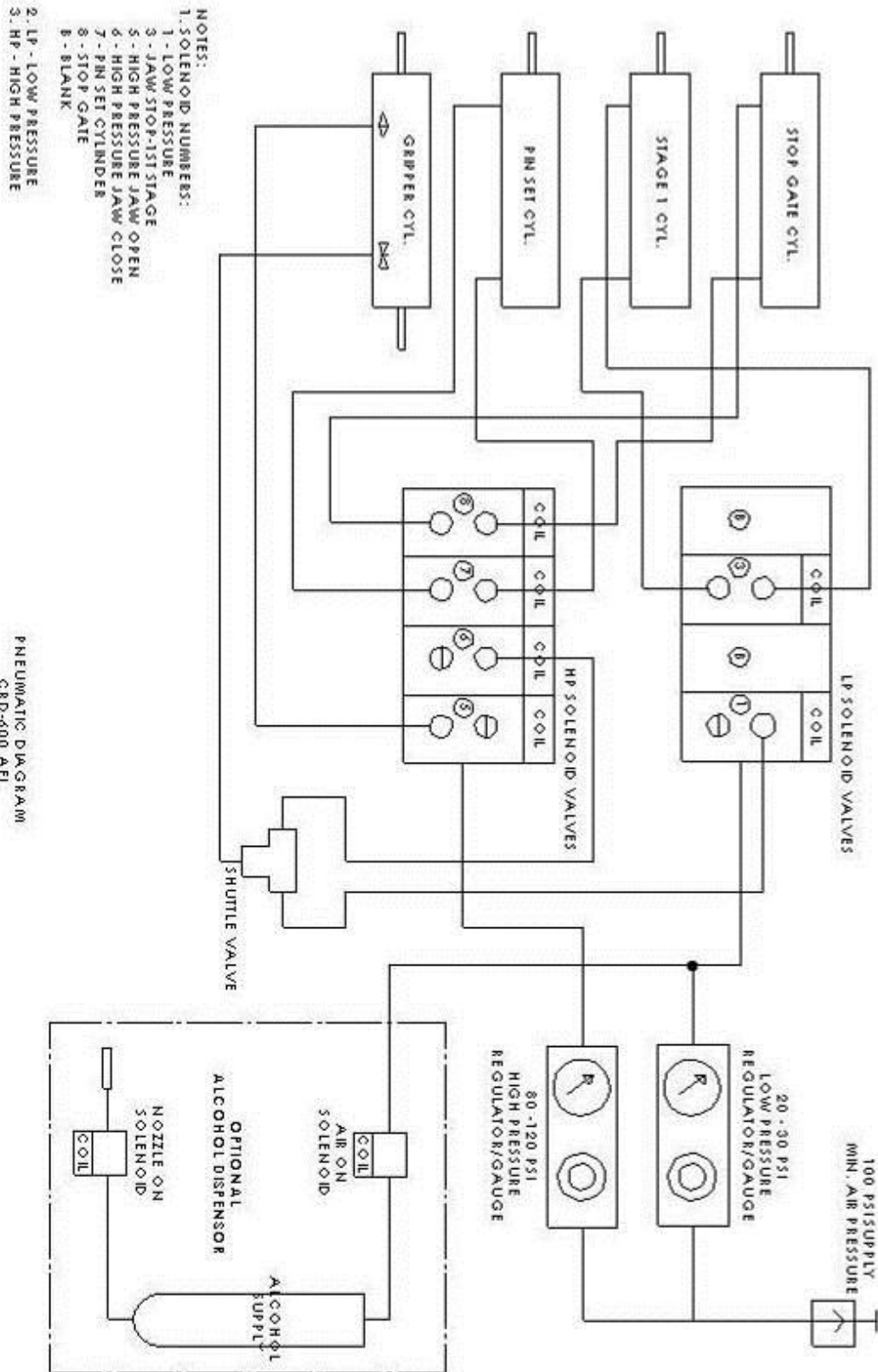

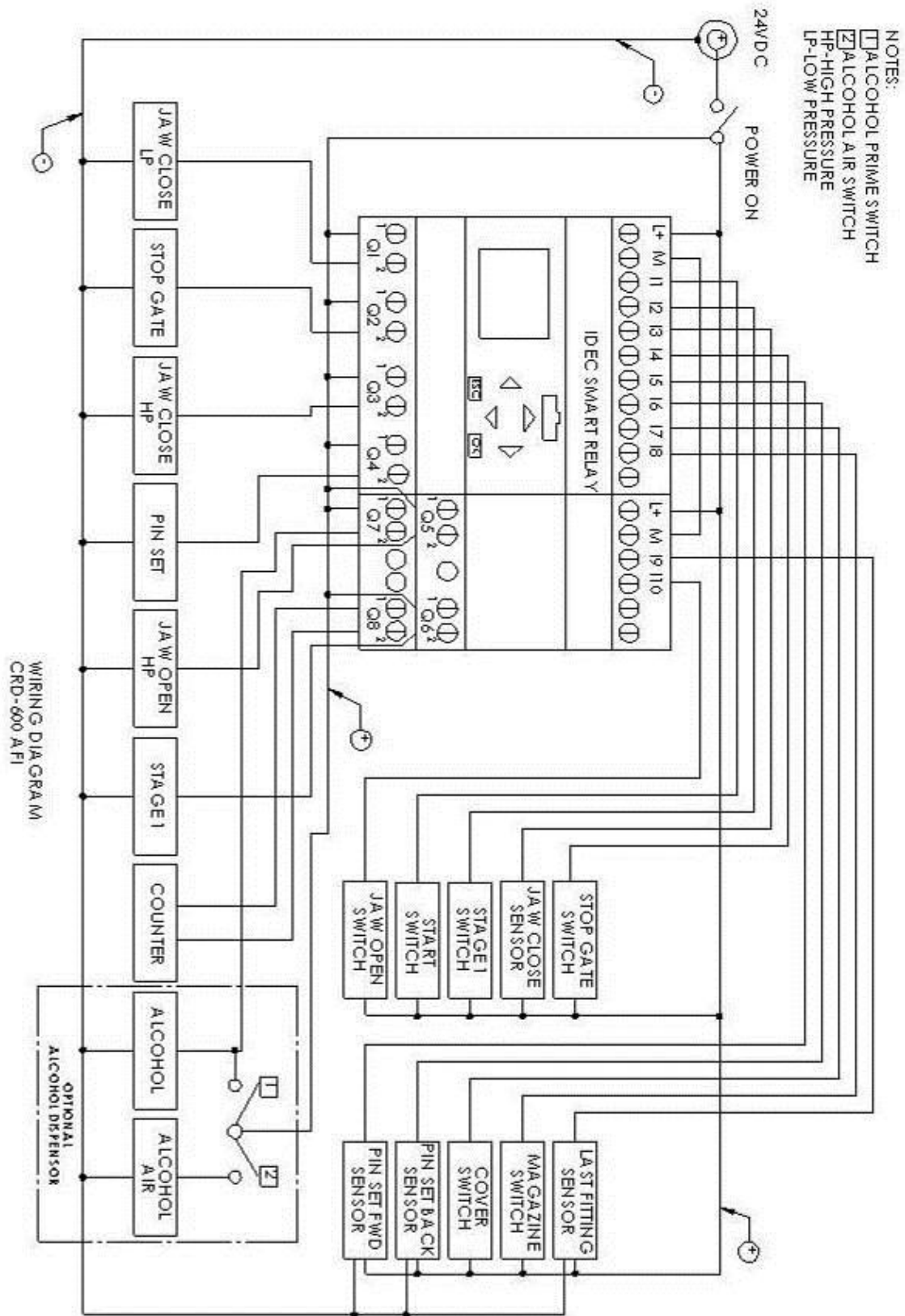

WIRING DIAGRAM
CRD-600 AFI

11.0 Warranty

11.1 Warranty

The manufacturer warrants the product manufactured by it, when properly installed, operated, applied and maintained in accordance with the procedures and recommendations outlined in the manufacturer's operation manual, to be free from defects in material or workmanship for a period as specified below, provided such defect is discovered and brought to the manufacturer's attention within the aforesaid warranty period.

The manufacturer will repair or replace any product or part determined to be defective by the manufacturer within the warranty period, provided such defect occurred in the normal service and not as a result of misuse, abuse, neglect or accident. Normal maintenance items requiring routine replacement are not warranted. The warranty covers parts and labor for the warranty period unless otherwise specified. Repair or replacement shall be made at the factory or the installation site, at the sole discretion of the manufacturer. Any service performed on the product by anyone other than the manufacturer must first be authorized by the manufacturer.

Unauthorized service voids the warranty and any resulting charge or subsequent claim will not be paid. Products repaired or replaced under warranty shall be warranted for the unexpired portion of the warranty applying to the original product.

The foregoing is the exclusive remedy of any buyer of the manufacturer's product. The maximum damages liability of the manufacturer is the original purchase price of the product or part.

THE FORGOING WARRANTY IS EXCLUSIVE AND IN LIEU OF ALL OTHER WARRANTIES, WHETHER WRITTEN, ORAL, OR STATUTORY, AND IS EXPRESSLY IN LIEU OF THE IMPLIED WARRANTY OF MERCHANTABILITY AND THE IMPLIED WARRANTY OF FITNESS FOR A PARTICULAR PURPOSE. THE MANUFACTURER SHALL NOT BE LIABLE FOR LOSS OR DAMAGE BY REASON OF STRICT LIABILITY IN TORT OR ITS NEGLIGENCE IN WHATEVER MANNER INCLUDING DESIGN, MANUFACTURE OR INSPECTION OR THE EQUIPMENT OR ITS FAILURE TO DISCOVER, REPORT, REPAIR, OR MODIFY LATENT DEFECTS INHERENT THEREIN.

THE MANUFACTURER, HIS REPRESENTATIVE OR DISTRIBUTOR SHALL NOT BE LIABLE FOR LOSS OF USE OF THE PRODUCT OR OTHER INCIDENTAL OR CONSEQUENTIAL COSTS, EXPENSES, OR DAMAGES INCURRED BY THE BUYER, WHETHER ARISING FROM BREACH OF WARRANTY, NEGLIGENCE OR STRICT LIABILITY IN TORT.

The manufacturer does not warrant any product, part, material, component, or accessory manufactured by others and sold or supplied in connection with the sale or manufacturer's products.

11.2 Warranty Period

Parts and labor for ninety (90) days from the date of shipment from the factory are covered. Freight to the factory on units that the manufacturer requests to be returned shall be paid by the purchaser, all return freight to be paid by the manufacturer; means of transportation to be specified by the manufacturer.

*For additional information contact: www.cleanroomdevices.com
Clean Room Devices, LLC
10855 Dover Street, Suite 100
Westminster, CO 80021
303-438-0853*

12.0 Alcohol Dispenser Option

The Alcohol Dispenser allows lubrication to be placed on the barb directly, allowing for a more reliable fitting insertion process. Shown are both the assembly instructions, as well as how to fill and refill the reservoirs.

IMPORTANT: READ BEFORE OPERATING ALCOHOL DISPENSER

Attaching Alcohol Reservoir to CRD600

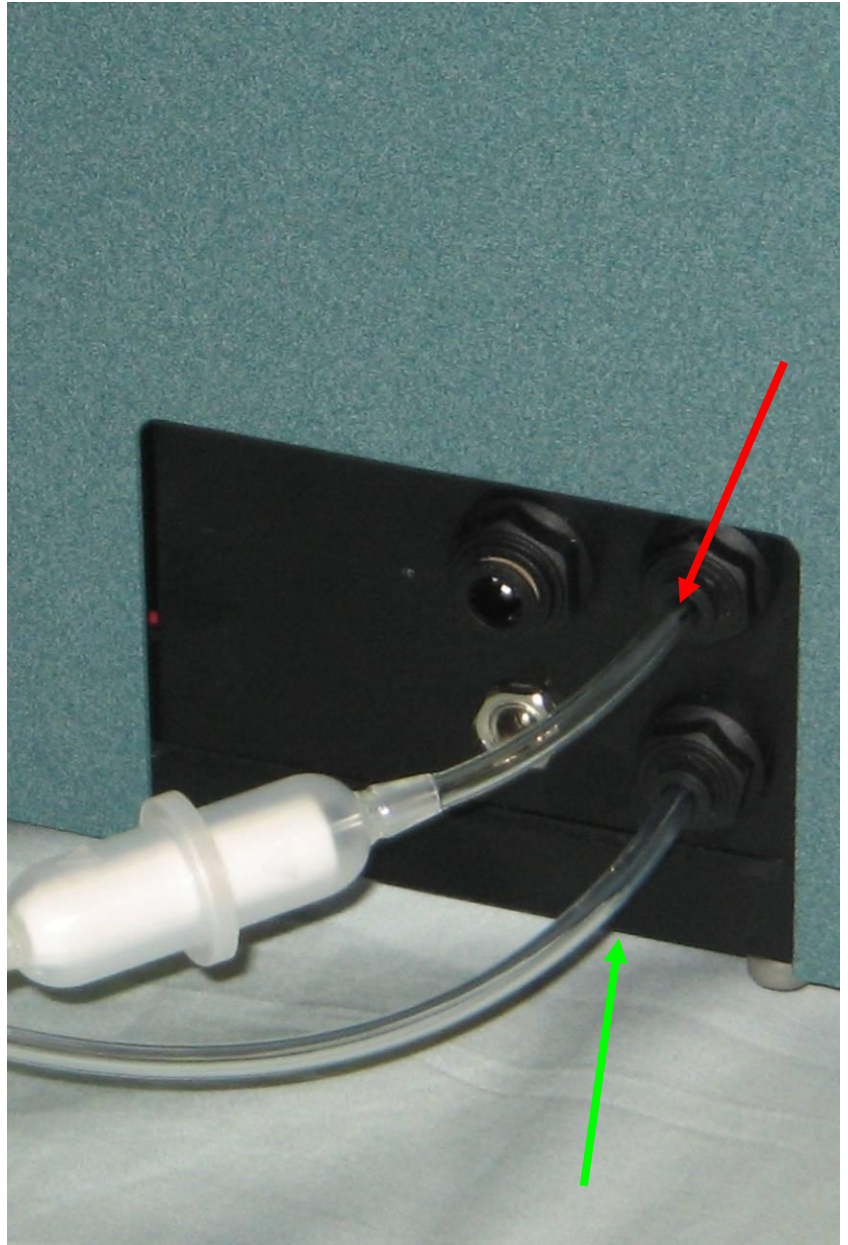

AIR IN



FLUID OUT



Filling Alcohol Reservoir:



Step 1



Step 2



Step 3

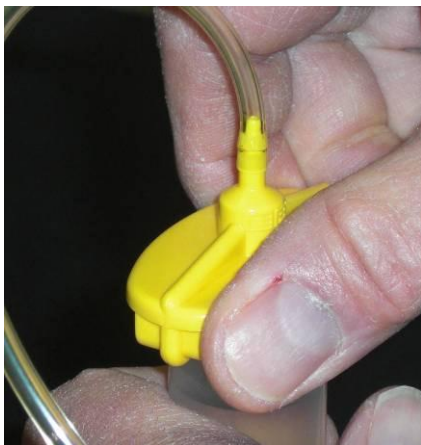

Step 4



Step 5



Step 6

- Step 1 – Disconnect air with quick-disconnect
- Step 2 – Twist open the barrel assembly
- Step 3 – Fill reservoir with alcohol
- Step 4 – Reconnect barrel assembly
- Step 5 – Reconnect quick-disconnect
- Step 6 – Prime alcohol system by pressing the red button switch on the CRD600 cover

Use adjustment knob on regulator to set pressure to 20-30 psi for the CRD600 unit. The alcohol is controlled by the low pressure regulator.

Caution: Setting the regulator pressure above 30 psi will result in pressure relief valve opening.

DO NOT BYPASS RELIEF VALVE

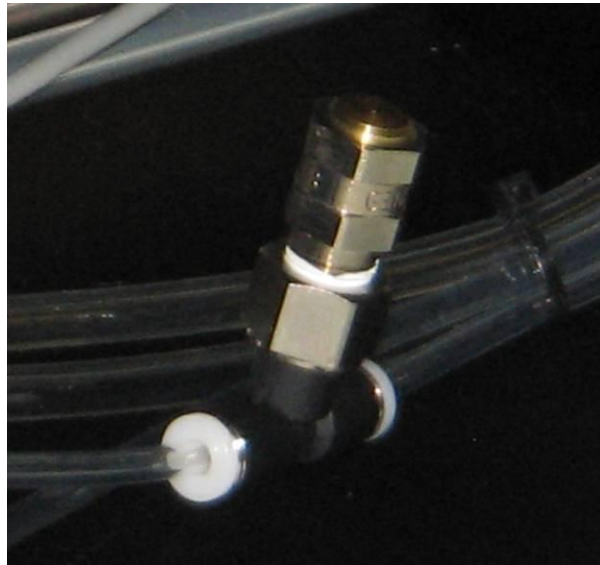

Alcohol Dispenser Relief Valve

Aiming the Alcohol Dispenser Nozzle:

Accurate aiming of the dispenser nozzle is critical to ensuring proper performance. Adjust the alcohol dispenser nozzle 1/16 – 1/8 of an inch in from the front of the barb, and at an oblique angle as shown in the diagram below. This alignment will ensure that alcohol will flow around both sides of the barb.

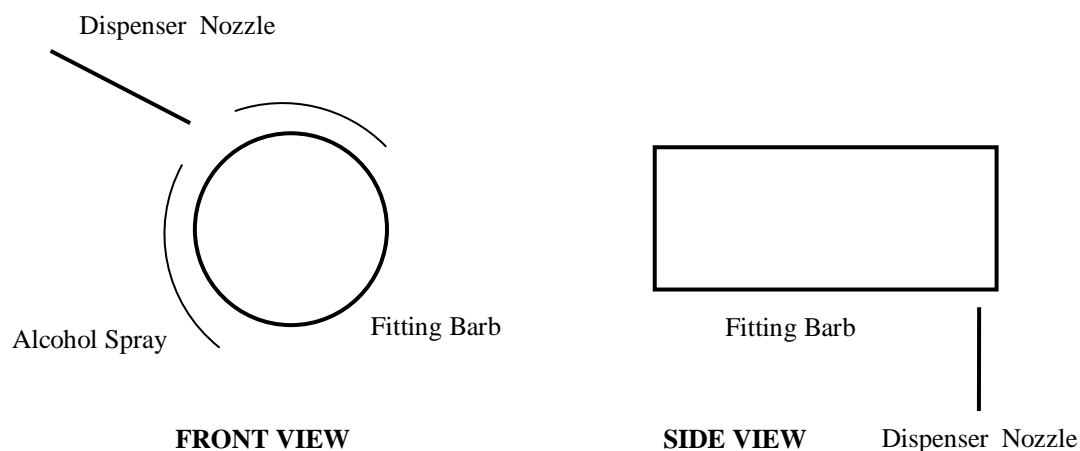

Proper latching of high capacity reservoir:

Align the arrows on the cap and body of the high capacity reservoir to ensure proper pressurization and functionality of alcohol dispenser.

WARNING: Failure to lock reservoir can result in malfunction of equipment and personal injury.



Reservoir in locked position

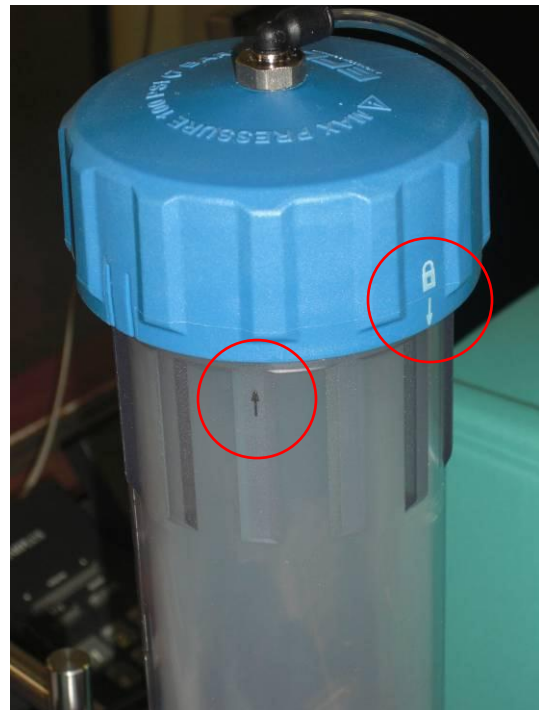

Reservoir in unlocked position

Attach large reservoir to CRD600 by following the same instructions for the small capacity reservoir as shown above on page 19.

Alcohol Dispenser System Components:

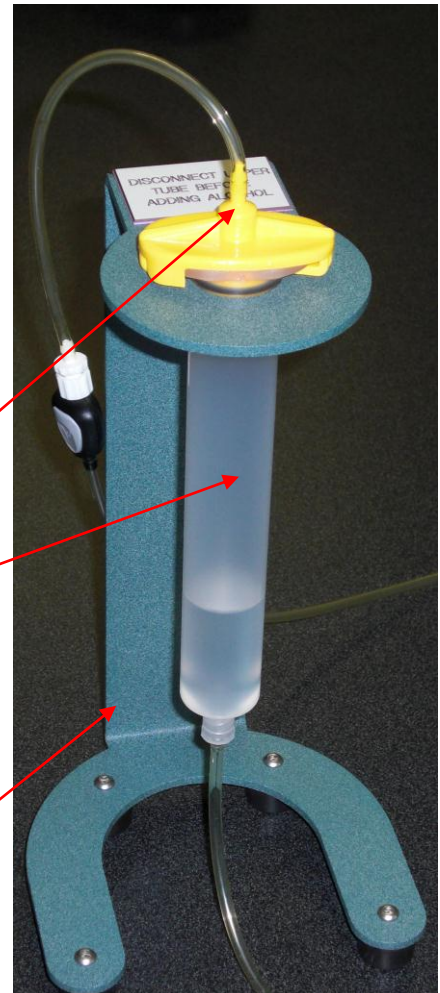
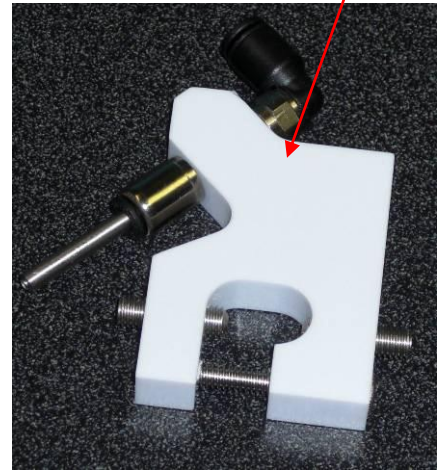
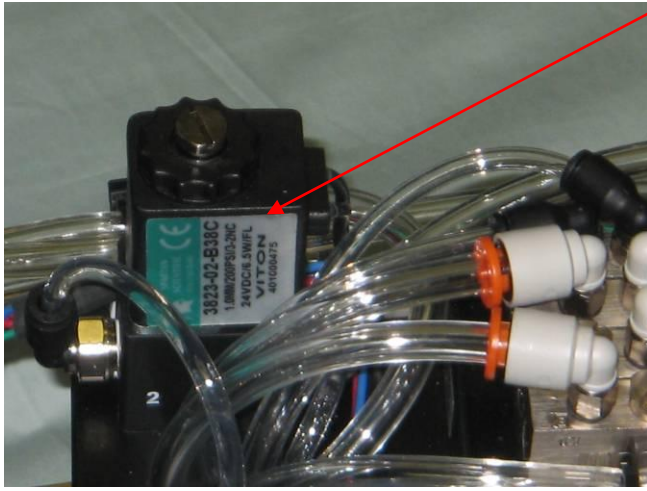

| Number | CRD# | Part Name |
|--------|---------|---------------------------|
| 1 | P00169 | Viton Valve |
| 2 | P00168 | Solenoid Air Valve |
| 3 | TS00136 | Nozzle Assembly & Bracket |
| 4 | P00178 | Barrel Adapter Assembly |
| 5 | P00177 | Alcohol Reservoir |
| 6 | P00176 | Dispenser Stand |